



US009159946B2

(12) **United States Patent**
Choi et al.

(10) **Patent No.:** **US 9,159,946 B2**
(45) **Date of Patent:** **Oct. 13, 2015**

(54) **ORGANIC LIGHT EMITTING DIODE DISPLAY HAVING AUXILIARY ELECTRODE**

(56) **References Cited**

(71) Applicant: **Samsung Display Co., Ltd.**, Yongin, Gyeonggi-Do (KR)
(72) Inventors: **Jin Baek Choi**, Anyang-si (KR); **Hyun Sung Bang**, Bucheon-si (KR); **Yeon Hwa Lee**, Yongin-si (KR); **Joon Gu Lee**, Seoul (KR); **Ji Young Choung**, Yongin-si (KR); **Young Woo Song**, Suwon-si (KR)

U.S. PATENT DOCUMENTS

| | | | | |
|--------------|------|---------|-----------------|---------|
| 4,723,838 | A * | 2/1988 | Aoki et al. | 349/47 |
| 5,953,085 | A * | 9/1999 | Shimada | 349/39 |
| 7,221,095 | B2 * | 5/2007 | Yamazaki et al. | 313/509 |
| 7,291,973 | B2 * | 11/2007 | Ishihara et al. | 313/505 |
| 7,728,510 | B2 | 6/2010 | Oh | |
| 8,598,777 | B2 * | 12/2013 | Fujioka et al. | 313/500 |
| 2007/0190887 | A1 * | 8/2007 | Sato et al. | 445/24 |

(Continued)

FOREIGN PATENT DOCUMENTS

| | | | |
|----|-----------------|----|---------|
| KR | 10-0712111 | B1 | 4/2007 |
| KR | 10-2010-0128794 | A | 12/2010 |
| KR | 10-2012-0019026 | A | 3/2012 |

(73) Assignee: **Samsung Display Co., Ltd.**, Gyeonggi-Do (KR)

(*) Notice: Subject to any disclaimer, the term of this patent is extended or adjusted under 35 U.S.C. 154(b) by 0 days.

Primary Examiner — Ida M Soward

(74) Attorney, Agent, or Firm — Knobbe Martens Olson & Bear LLP

(21) Appl. No.: **14/205,088**

(22) Filed: **Mar. 11, 2014**

(65) **Prior Publication Data**

US 2015/0102294 A1 Apr. 16, 2015

(30) **Foreign Application Priority Data**

Oct. 15, 2013 (KR) 10-2013-0122831

(51) **Int. Cl.**

H01L 51/52 (2006.01)
H01L 51/56 (2006.01)
H01L 27/32 (2006.01)

(52) **U.S. Cl.**

CPC **H01L 51/5203** (2013.01); **H01L 27/3244** (2013.01); **H01L 51/56** (2013.01); **H01L 51/5212** (2013.01); **H01L 51/5284** (2013.01); **H01L 2251/5315** (2013.01)

(58) **Field of Classification Search**

CPC H01L 51/5203; H01L 51/5212; H01L 51/5284; H01L 2251/5315

See application file for complete search history.

(57) **ABSTRACT**

In an aspect, an organic light emitting diode display including: a substrate; a first electrode and an auxiliary electrode positioned on the substrate and separated from each other; an absorption electrode positioned on the auxiliary electrode; an organic emission layer positioned on the first electrode and having a contact hole exposing the auxiliary electrode and the absorption electrode; and a second electrode positioned on the organic emission layer and connected to the auxiliary electrode and the absorption electrode through the contact hole is provided. In an aspect, the organic light emitting diode (OLED) display may minimize the voltage drop of the driving power passing through the large-sized electrode of the thin film for driving the organic emission layer, and may simplify the removal process of the organic emission layer on the auxiliary electrode by adding the absorption electrode on the auxiliary electrode.

17 Claims, 15 Drawing Sheets

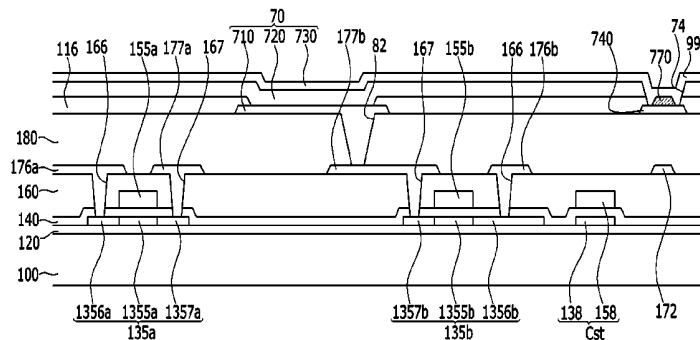

(56)

References Cited

U.S. PATENT DOCUMENTS

| | | | | | | | | | |
|--------------|------|---------|-------------------------|---------|--------------|------|---------|------------------|---------|
| 2008/0284323 | A1 * | 11/2008 | Kashiwabara et al. | 313/504 | 2014/0099738 | A1 * | 4/2014 | Lee et al. | 438/22 |
| 2011/0248297 | A1 * | 10/2011 | Ito | 257/93 | 2014/0104743 | A1 * | 4/2014 | Park | 361/234 |
| 2012/0252303 | A1 * | 10/2012 | Otsuka et al. | 445/58 | 2014/0110680 | A1 * | 4/2014 | Choe | 257/40 |
| 2013/0056784 | A1 * | 3/2013 | Lee et al. | 257/99 | 2014/0239262 | A1 * | 8/2014 | Kim et al. | 257/40 |
| | | | | | 2014/0367705 | A1 * | 12/2014 | Bibl et al. | 257/88 |

* cited by examiner

FIG. 1

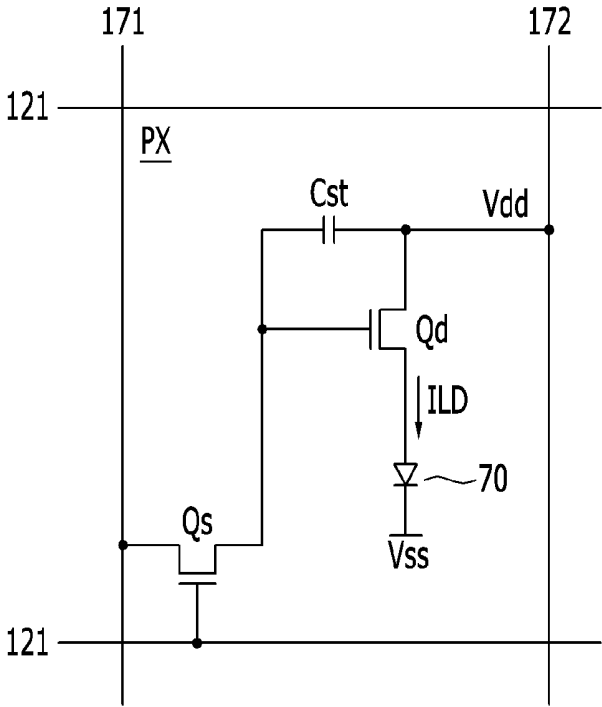

FIG. 3

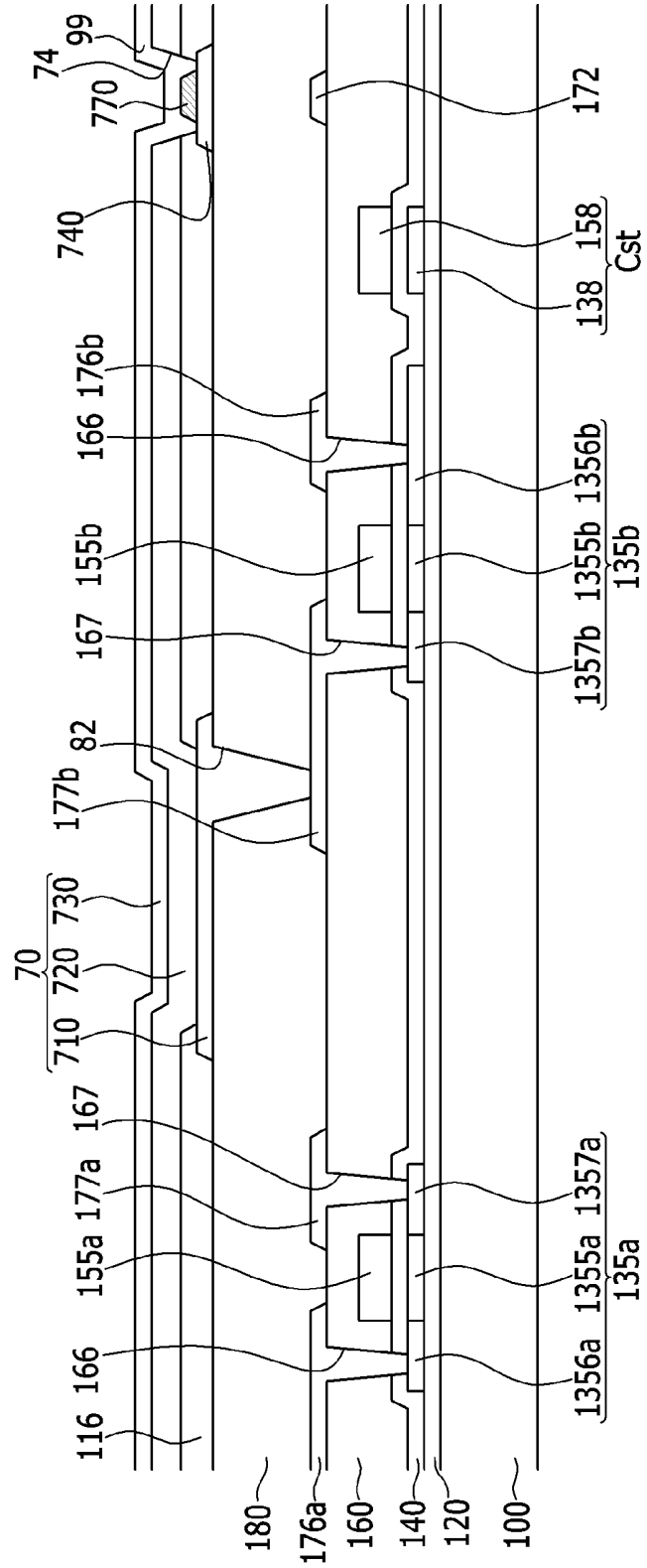

FIG. 4

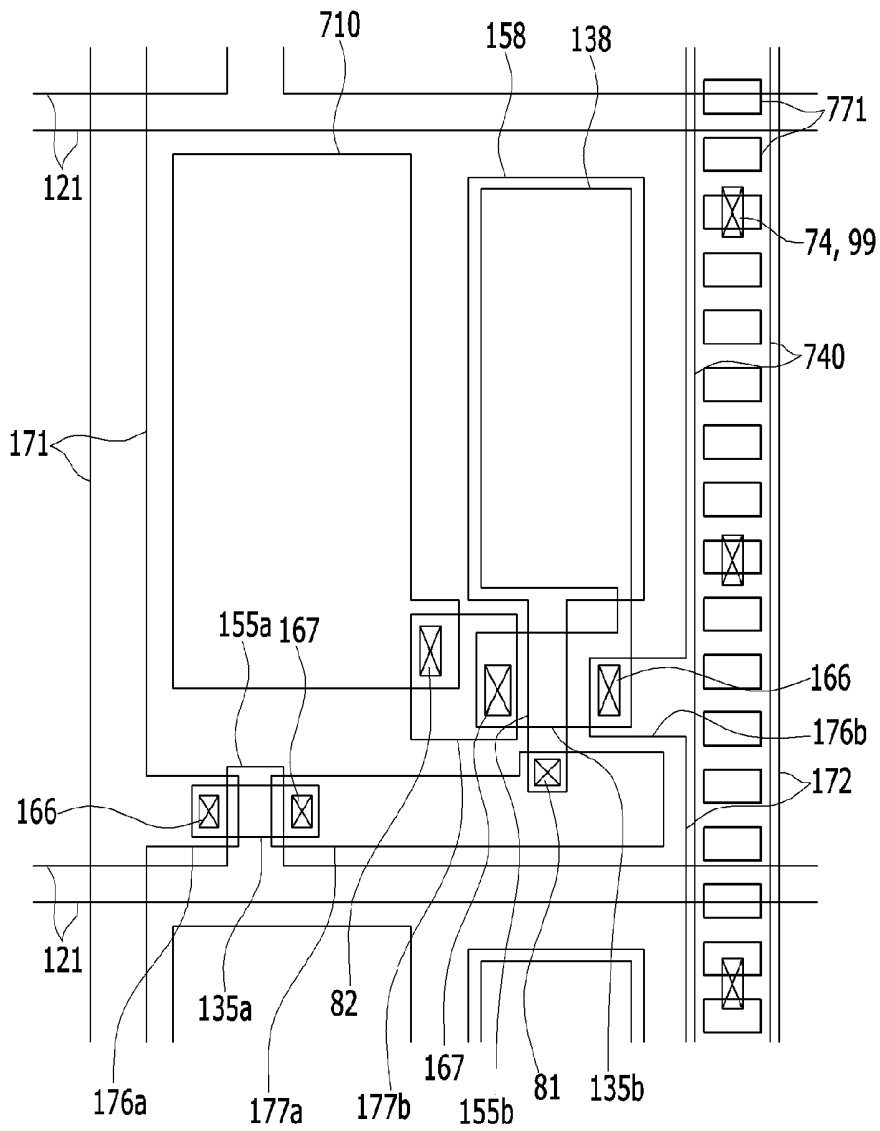

FIG. 5

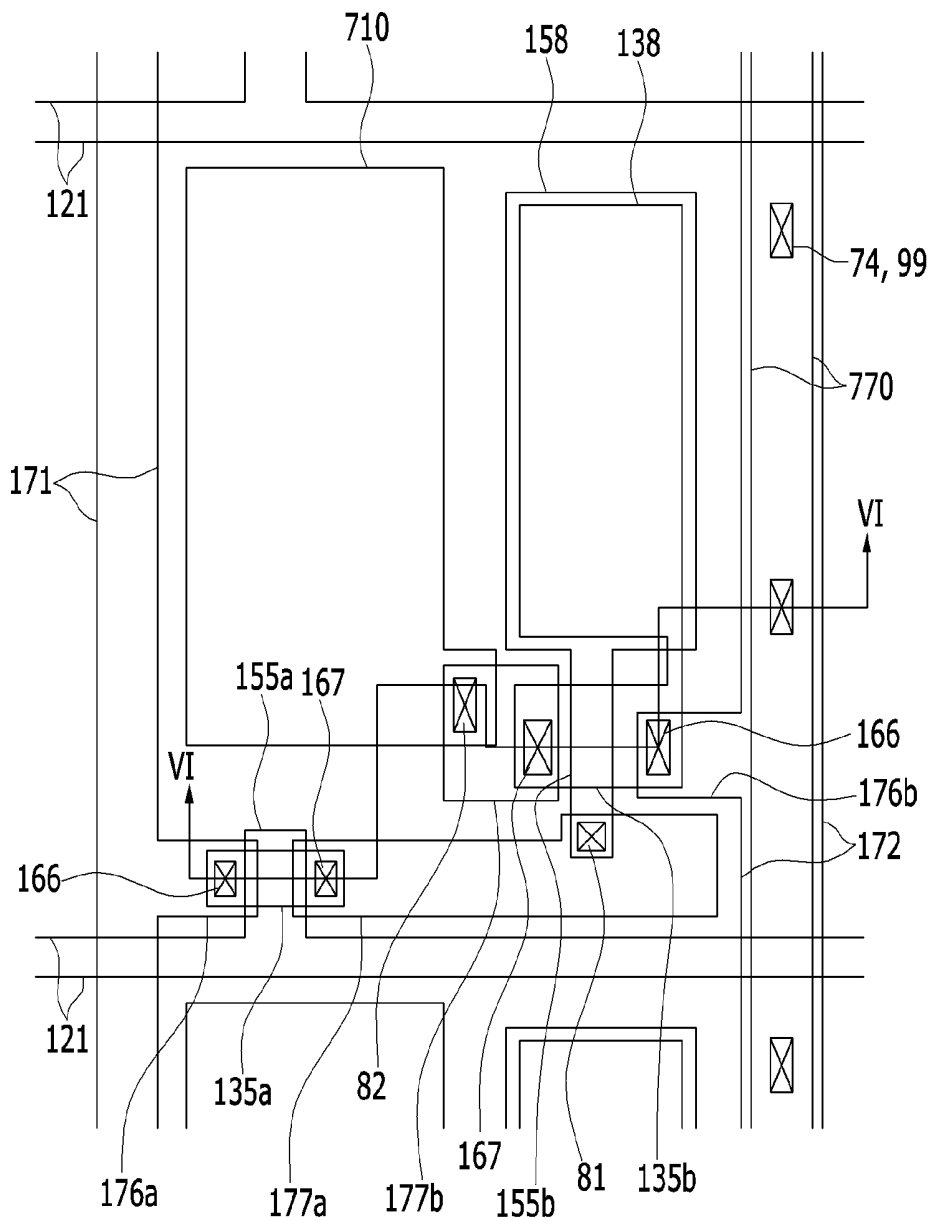

FIG.6

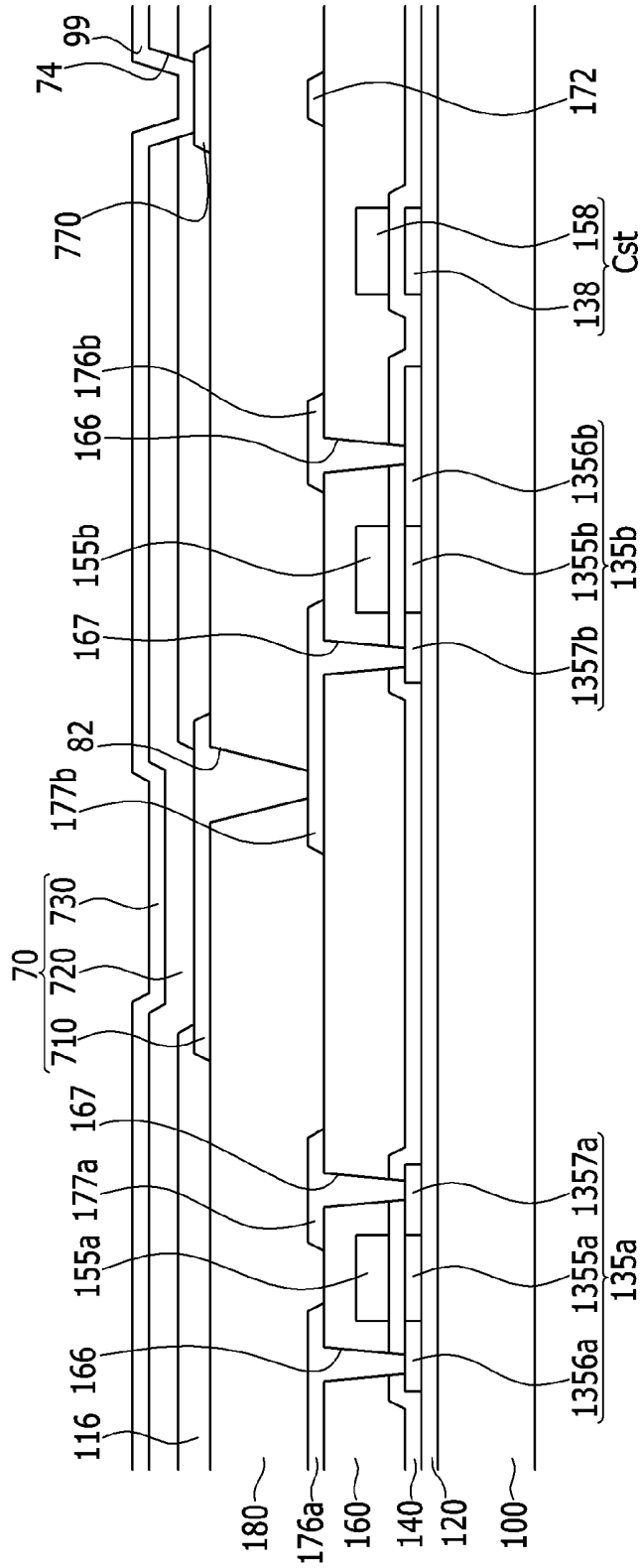

FIG. 7

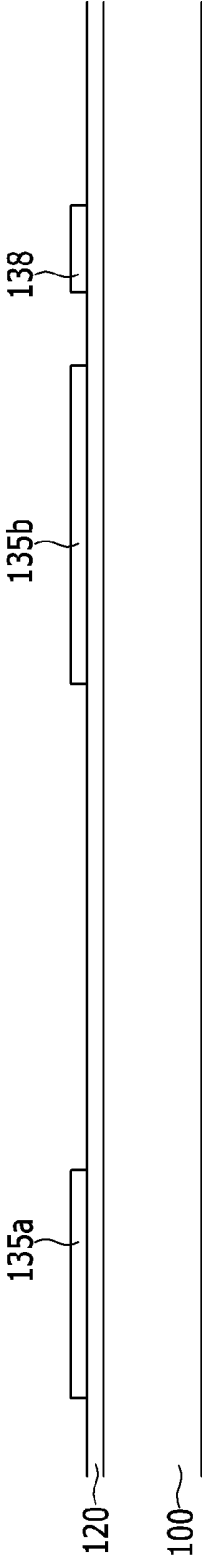

FIG. 8

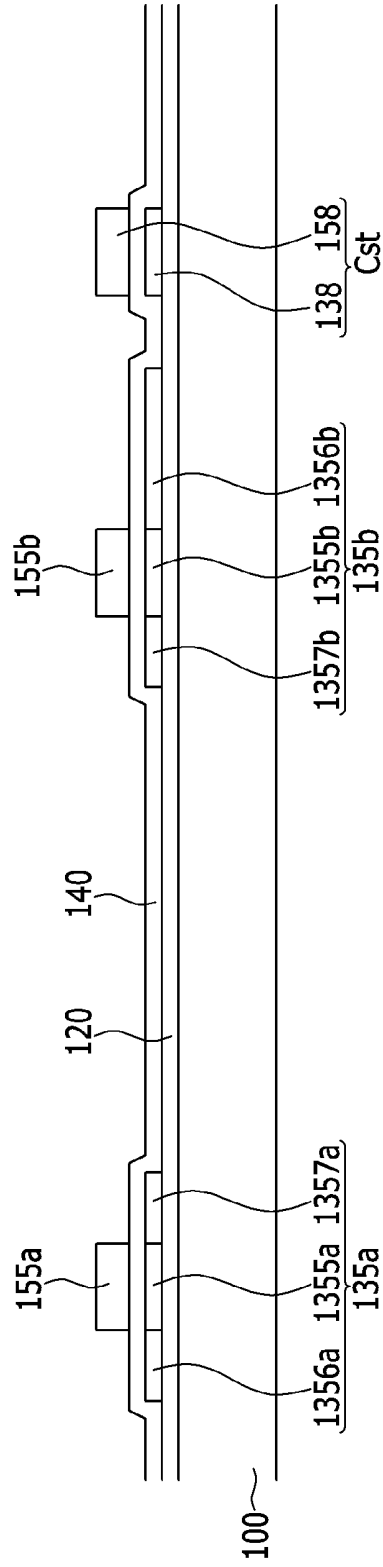

FIG. 10

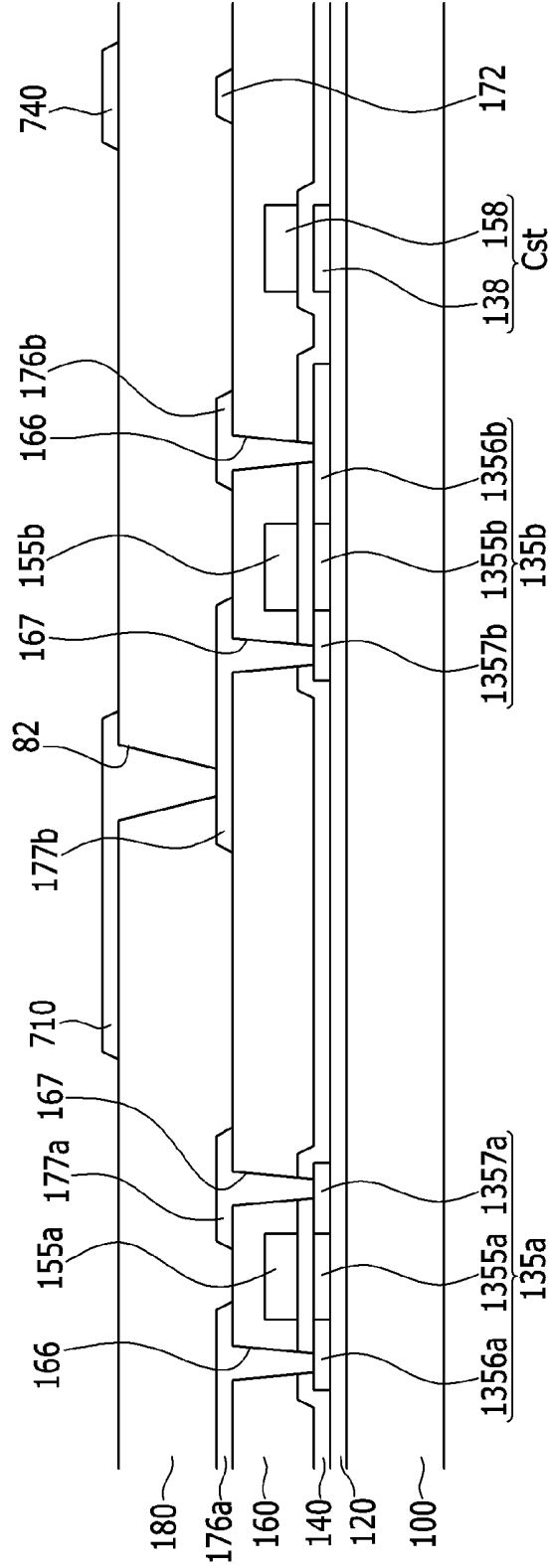

FIG. 11

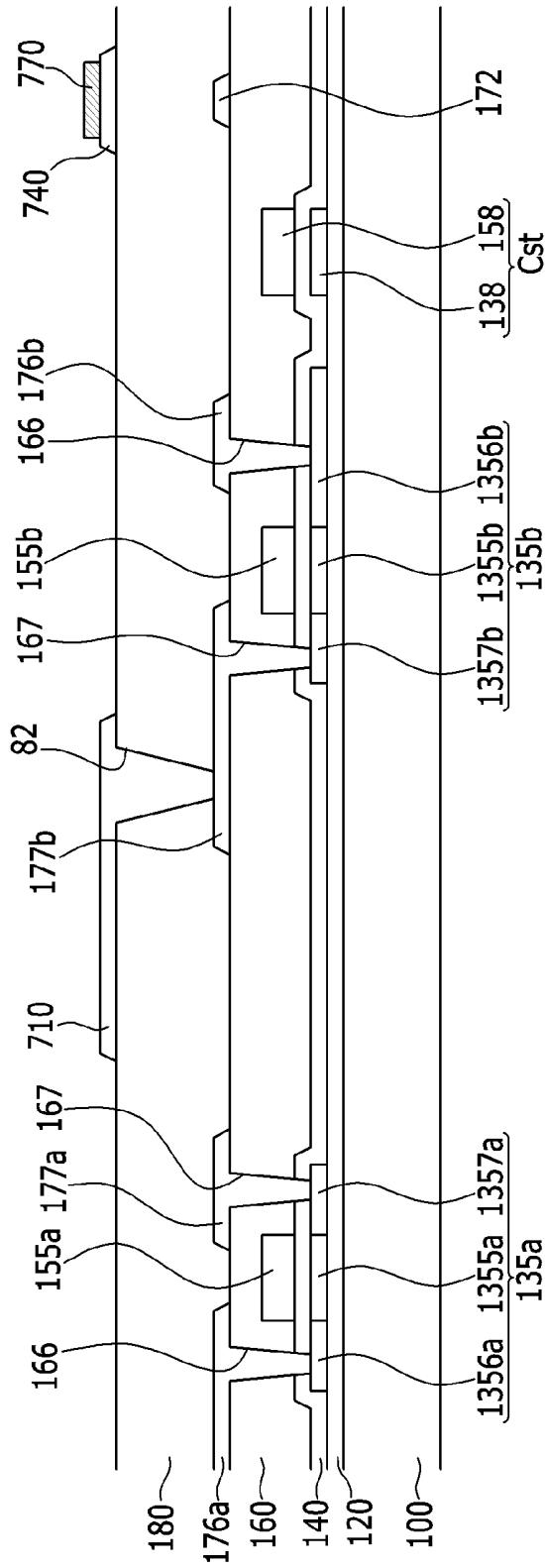

FIG.13

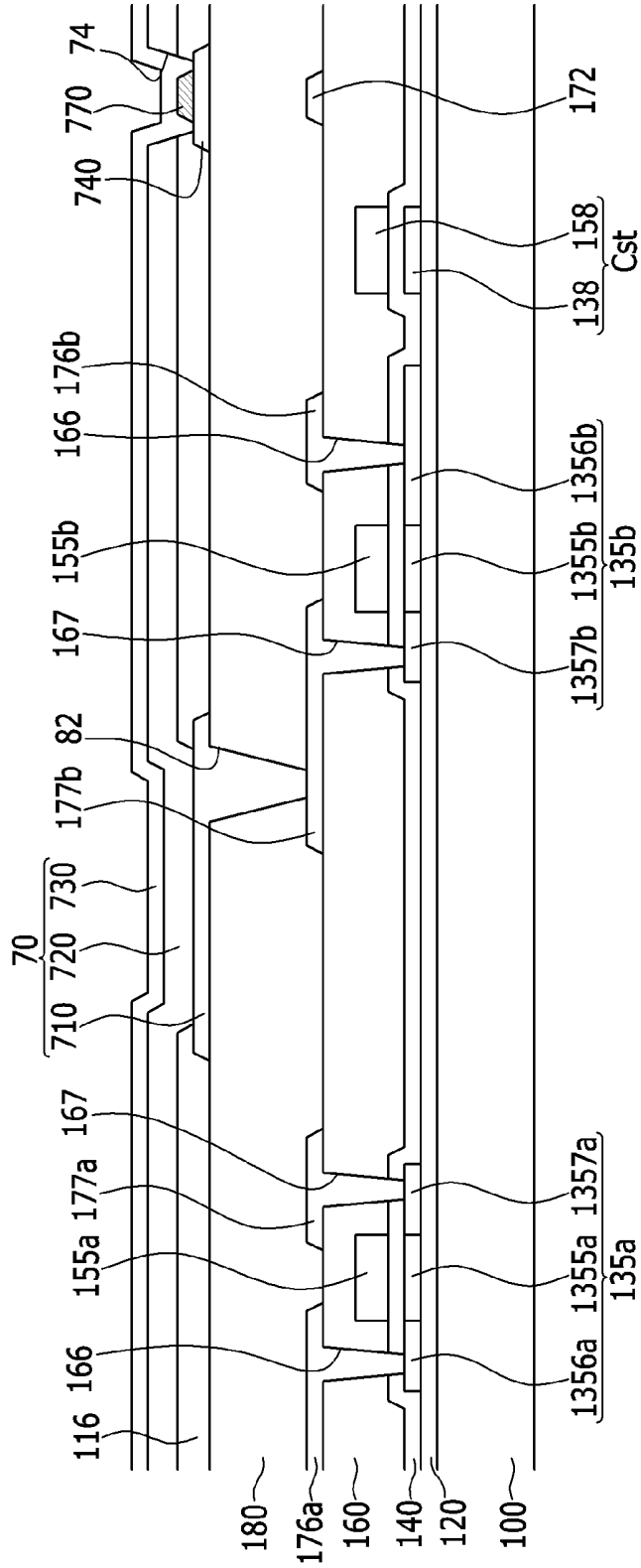

FIG.14

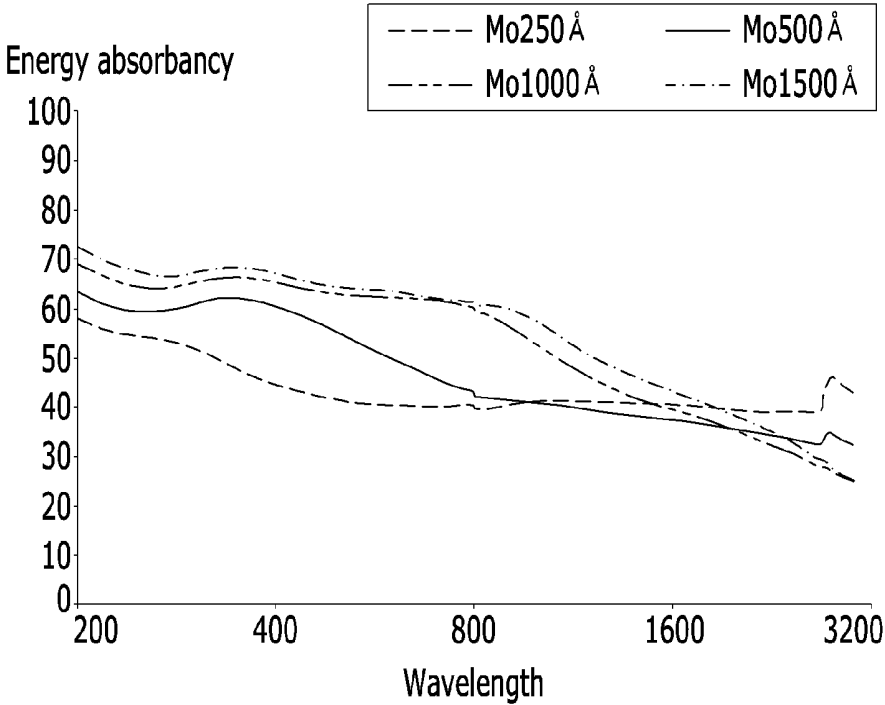
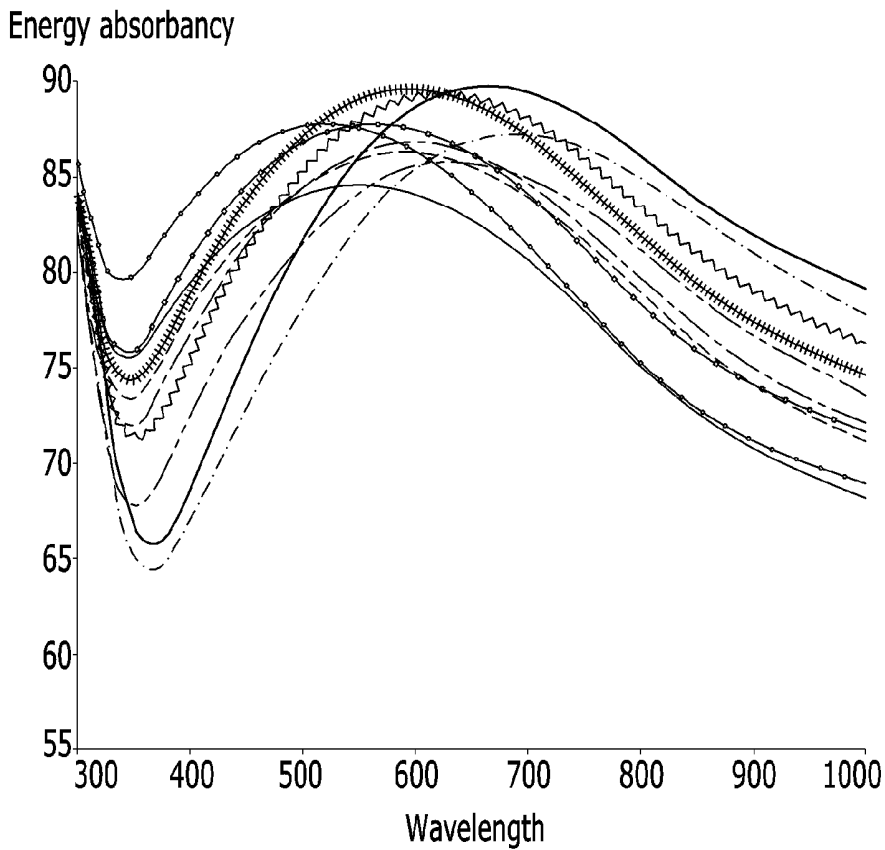
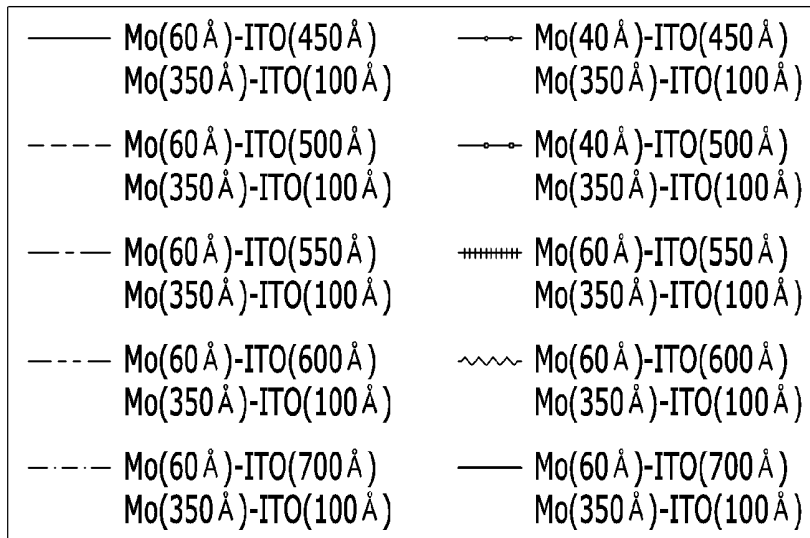

FIG.15



ORGANIC LIGHT EMITTING DIODE DISPLAY HAVING AUXILIARY ELECTRODE

INCORPORATION BY REFERENCE TO ANY PRIORITY APPLICATIONS

Any and all priority claims identified in the Application Data Sheet, or any correction thereto, are hereby incorporated by reference under 37 CFR 1.57. For example, this application claims priority to and the benefit of Korean Patent Application No. 10-2013-0122831 filed in the Korean Intellectual Property Office on Oct. 15, 2013, the disclosure of which is incorporated herein by reference in its entirety.

BACKGROUND

1. Field

This disclosure relates to an organic light emitting diode display and a manufacturing method thereof. For example, the present disclosure relates to an organic light emitting diode display including an auxiliary electrode and an absorption electrode.

2. Description of the Related Technology

An organic light emitting diode (OLED) display has been recently spotlighted as a display device for displaying images.

A conventional OLED display typically includes a first electrode, an organic emission layer disposed on the first electrode, and a second electrode disposed on the organic emission layer.

An OLED display may be classified into a front emission type, a rear emission type, and a dual emission type. The front emission type OLED display typically has a structure in which a second electrode of an organic light emitting element is formed over the entire area of a substrate where the organic light emitting element is formed in a thin film shape in order to minimize deterioration of luminance of light generated from an organic emission layer.

However, a voltage drop may occur in driving power passing through the second electrode for driving the organic emission layer due to electrical resistance of the second electrode since the second electrode formed as a thin film is formed over the entire area of the substrate in the front emission type of OLED display.

The above information disclosed in this Background section is only for enhancement of understanding of the background of the disclosure and therefore it may contain information that does not form the prior art that is already known to a person of ordinary skill in the art.

SUMMARY

Some embodiments provide an organic light emitting diode (OLED) display that can minimize a voltage drop in driving power passing through a large-sized thin film electrode for driving an organic emission layer and can simplify a removal process of the organic emission layer on an auxiliary electrode by adding an absorption electrode on the auxiliary electrode, and a manufacturing method thereof.

Some embodiments provide an organic light emitting diode display including: a substrate; a first electrode and an auxiliary electrode positioned on the substrate and separated from each other; an absorption electrode positioned on the auxiliary electrode; an organic emission layer positioned on the first electrode and having a contact hole exposing the auxiliary electrode and the absorption electrode; and a second

electrode positioned on the organic emission layer and connected to the auxiliary electrode and the absorption electrode through the contact hole.

In some embodiments, the second electrode may contact an etched surface of the contact hole, an upper surface of the auxiliary electrode, and an upper surface and a side surface of the absorption electrode.

In some embodiments, the absorption electrode may be made of one selected from molybdenum (Mo), titanium (Ti), tungsten (W), and chromium (Cr).

In some embodiments, the absorption electrode may be formed of a single layer or multiple layers.

In some embodiments, the absorption electrode may have a thickness of 300-1500 Å when the absorption electrode is formed of a single layer.

In some embodiments, an oxide layer may be further formed between the absorption electrode of the multiple layers when the absorption electrode is formed of multiple layers.

In some embodiments, the absorption electrode may be formed of dual layers, and an upper layer and a lower layer of the absorption electrode may respectively have thicknesses of 40-100 Å and 300-1000 Å.

In some embodiments, the oxide layer may be ITO or IZO. In some embodiments, the absorption electrode may be formed with a line shape or a dot shape in a direction parallel to the auxiliary electrode on the auxiliary electrode.

In some embodiments, the organic light emitting diode display may further include: a gate line positioned on the substrate; a data line and a driving voltage line insulated from and intersecting the gate line and separated from each other; a switching thin film transistor connected to the gate line and the data line; and a driving thin film transistor connected to the switching thin film transistor and the driving voltage line, wherein the first electrode may be connected to a drain electrode of the driving thin film transistor.

Some embodiments provide an organic light emitting diode display includes: a substrate; a first electrode and an absorption electrode made of one selected from molybdenum (Mo), titanium (Ti), tungsten (W), and chromium (Cr), positioned on the substrate and separated from each other; an organic emission layer positioned on the first electrode and a contact hole exposing the absorption electrode; and a second electrode positioned on the organic emission layer and connected to the absorption electrode through the contact hole, wherein the absorption electrode is connected to the second electrode thereby having a function of an auxiliary electrode of the first electrode.

Some embodiments provide a manufacturing method of an organic light emitting diode display includes: forming a thin film transistor on a substrate; forming a first electrode connected to the thin film transistor and an auxiliary electrode separated from the first electrode; forming an absorption electrode on the auxiliary electrode; forming an organic emission layer on the first electrode, the auxiliary electrode, and the absorption electrode; irradiating an energy light source to the organic emission layer to etch the organic emission layer, thereby forming a contact hole having an opening exposing the auxiliary electrode and the absorption electrode; and depositing a metal layer on the organic emission layer to form a second electrode contacting an upper surface of the auxiliary electrode, an upper surface of the absorption electrode, and an etched surface of the opening in the contact hole.

In some embodiments, the etching of the organic emission layer may use a laser, a flash lamp, or a tungsten halogen lamp as an energy light source.

In some embodiments, the organic light emitting diode (OLED) display may minimize the voltage drop of the driving power passing through the large-sized electrode of the thin film for driving the organic emission layer, and may simplify the removal process of the organic emission layer on the auxiliary electrode by adding the absorption electrode on the auxiliary electrode.

BRIEF DESCRIPTION OF THE DRAWINGS

FIG. 1 is a circuit diagram of a pixel circuit of an organic light emitting diode display according to an exemplary embodiment.

FIG. 2 is a layout view of one pixel of the organic light emitting diode display of FIG. 1.

FIG. 3 is a cross-sectional view taken along the line III-III of FIG. 2.

FIG. 4 is a layout view of one pixel of an organic light emitting diode display according to another exemplary embodiment.

FIG. 5 is a layout view of one pixel of an organic light emitting diode display according to another exemplary embodiment.

FIG. 6 is a cross-sectional view taken along the line VI-VI of FIG. 5.

FIGS. 7 to 13 are cross-sectional views sequentially showing a manufacturing method of an organic light emitting diode display according to another exemplary embodiment.

FIG. 14 is a graph showing a result of measuring absorptency according to a wavelength of light source energy for an absorption electrode that is formed of a single layer.

FIG. 15 is a graph showing a result of measuring absorptency according to a wavelength of light source energy for an absorption electrode that is formed of multiple layers.

DETAILED DESCRIPTION

The present disclosure will be described more fully hereinafter with reference to the accompanying drawings, in which exemplary embodiments of the invention are shown. As those skilled in the art would realize, the described embodiments may be modified in various different ways, all without departing from the spirit or scope of the present embodiments.

In the drawings, the thickness of layers, films, panels, regions, etc., are exaggerated for clarity. Like reference numerals designate like elements throughout the specification. It will be understood that when an element such as a layer, film, region, or substrate is referred to as being "on" another element, it can be directly on the other element or intervening elements may also be present. In contrast, when an element is referred to as being "directly on" another element, there are no intervening elements present.

An organic light emitting diode display and a manufacturing method thereof according to an exemplary embodiment will be described with reference to accompanying drawings.

FIG. 1 is a circuit diagram of a pixel circuit of an organic light emitting diode display according to an exemplary embodiment.

As shown in FIG. 1, an organic light emitting diode display according to the exemplary embodiment includes a plurality of signal lines **121**, **171**, and **172** and a plurality of pixels (PX) connected thereto and arranged in an approximate matrix form.

The signal lines include a plurality of gate lines **121** transferring a gate signal (or a scan signal), a plurality of data lines **171** transferring a data signal, and a plurality of driving volt-

age lines **172** transferring a driving voltage V_{dd}. The gate lines **121** extend in an approximate row direction and are almost parallel to each other, and vertical direction portions of the data lines **171** and the driving voltage lines **172** extend in an approximate column direction and are almost parallel to each other.

Each pixel PX includes a switching thin film transistor Q_s, a driving thin film transistor Q_d, a storage capacitor C_{st}, and an organic light emitting diode (OLED) **70**.

The switching thin film transistor Q_s has a control terminal, an input terminal, and an output terminal, the control terminal is connected to the gate line **121**, the input terminal is connected to the data line **171**, and the output terminal is connected to the driving thin film transistor Q_d. The switching thin film transistor Q_s transfers the data signal applied to the data line **171** to the driving thin film transistor Q_d in response to the scan signal applied to the gate line **121**.

Further, the driving thin film transistor Q_d has a control terminal, an input terminal, and an output terminal, and the control terminal is connected to the switching thin film transistor Q_s, the input terminal is connected to the driving voltage line **172**, and the output terminal is connected to the organic light emitting diode **70**. The driving thin film transistor Q_d allows an output current (ILD) having a varying magnitude according to a voltage applied between the control terminal and the output terminal to flow.

The capacitor C_{st} is connected between the control terminal and the input terminal of the driving thin film transistor Q_d. This capacitor C_{st} charges the data signal applied to the control terminal of the driving thin film transistor Q_d and maintains the data signal after the switching thin film transistor Q_s is turned off.

The organic light emitting diode LD has an anode connected to the output terminal of the driving thin film transistor Q_d, and a cathode connected to a common voltage V_{ss}. The organic light emitting diode (LD) displays an image by emitting light while changing the intensity thereof according to the output current (ILD) of the driving thin film transistor Q_d.

Further, the connection relationship of the thin film transistors Q_s and Q_d, the capacitor C_{st}, and the organic light emitting diode **70** may be changed.

The organic light emitting diode display in which the second electrode as a thin film type is entirely formed on the substrate including the organic light emitting element uses an auxiliary electrode forming the second electrode to prevent generation of a voltage drop to a power source passing through the second electrode to drive the organic emission layer by electric resistance of the second electrode.

However, a process of removing an organic layer to contact the auxiliary electrode and the first electrode is required and energy absorptency of the organic layer is low such that energy transmitting efficiency is largely decreased, and the removal process must be performed in a vacuum condition.

Next, an organic light emitting diode display according to an exemplary embodiment of the present invention will be described with reference to FIG. 2 and FIG. 3.

FIG. 2 is a layout view of one pixel of the organic light emitting diode display of FIG. 1, and FIG. 3 is a cross-sectional view taken along the line III-III of FIG. 2.

As shown in FIG. 3, a buffer layer **120** is formed on a substrate **100**.

In some embodiments, the substrate **100** may be an insulating substrate made of glass, quartz, ceramic, or a polymer material, or the substrate **100** may be a metallic substrate made of a stainless steel. In some embodiments, the polymer material may be an organic material selected from a group consisting of polyethersulfone (PES), polyacrylate (PAR),

polyetherimide (PEI), polyethylene naphthalate (PEN), polyethylene terephthalate (PET), polyphenylene sulfide (PPS), polyallylate, polyimide, polycarbonate (PC), cellulose triacetate (TAC), and cellulose acetate propionate (CAP) that are insulating organic materials.

In some embodiments, the buffer layer **120** is formed on the substrate **100**.

In some embodiments, the buffer layer **120** may be formed to have a structure of a single layer of a silicon oxide (SiO_x) or a silicon nitride (SiN_x), or a plurality of layers where a silicon nitride (SiN_x) and a silicon oxide (SiO_x) are laminated. The buffer layer acts to prevent unnecessary components such as an impurity or moisture from permeating, and planarizes the surface.

In some embodiments, a first semiconductor **135a** and a second semiconductor **135b** may both be made of polysilicon and a first capacitor electrode **138** are formed on the buffer layer **120**.

In some embodiments, the first semiconductor **135a** and the second semiconductor **135b** may be divided into channel regions **1355a** and **1355b**, and source regions **1356a** and **1356b** and drain regions **1357a** and **1357b** respectively formed on both sides of the channel regions **1355a** and **1355b**. In some embodiments, the channel regions **1355a** and **1355b** of the first semiconductor **135a** and the second semiconductor **135b** are polysilicon into which impurities have not been doped, that is, intrinsic semiconductors. In some embodiments, the source regions **1356a** and **1356b** and the drain regions **1357a** and **1357b** of the first semiconductor **135a** and the second semiconductor **135b** are polysilicon into which conductive impurities have been doped, that is, impurity semiconductors.

In some embodiments, the impurities doped into the source regions **1356a** and **1356b**, the drain regions **1357a** and **1357b**, and the first capacitor electrode **138** can be either p-type impurities or n-type impurities.

In some embodiments, a gate insulating layer **140** is formed on the first semiconductor **135a**, the second semiconductor **135b**, and the first capacitor electrode **138**. In some embodiments, the gate insulating layer **140** can be a single layer or a plurality of layers including at least one of tetraethyl orthosilicate (TEOS), a silicon nitride (SiN_x), and a silicon oxide (SiO_x).

In some embodiments, the gate line **121**, a second gate electrode **155b**, and a second capacitor electrode **158** are formed on the gate insulating layer **140**.

In some embodiments, the gate line **121** (shown in the perspective of FIG. 2) lengthily extends in a horizontal direction and transfers a gate signal, and includes a first gate electrode **155a** that is protruded from the gate line **121** to the first semiconductor **135a**.

In some embodiments, the first gate electrode **155a** and the second gate electrode **155b** overlap the respective channel regions **1355a** and **1355b**, and the second capacitor electrode **158** overlaps the first capacitor electrode **138**.

In some embodiments, each of the second capacitor electrode **158**, the first gate electrode **155a**, and the second gate electrode **155b** can have a single layer of a plurality of layers made of molybdenum, tungsten, copper, aluminum, or an alloy thereof.

In some embodiments, the first capacitor electrode **138** and the second capacitor electrode **158** form a capacitor Cst using the gate insulating layer **140** as a dielectric material.

In some embodiments, a first interlayer insulating layer **160** is formed on the first gate electrode **155a**, the second gate electrode **155b**, and the second capacitor electrode **158**. In some embodiments, the first interlayer insulating layer **160**,

like the gate insulating layer **140**, can be made of tetraethyl orthosilicate (TEOS), a silicon nitride (SiN_x), or a silicon oxide (SAX).

In some embodiments, the first interlayer insulating layer **160** and the gate insulating layer **140** include a source contact hole **166** and a drain contact hole **167** through which the source regions **1356a** and **1356b** and the drain regions **1357a** and **1357b** are exposed, respectively.

In some embodiments, the data lines **171** including a first source electrode **176a**, the driving voltage lines **172** including a second source electrode **176b**, a first drain electrode **177a** (not shown), and a second drain electrode **177b** are formed on the first interlayer insulating layer **160**.

In some embodiments, the data line **171** transmits a data signal and extends in a direction crossing the gate line **121**.

In some embodiments, the driving voltage line **172** transmits a predetermined voltage, and extends in the same direction as that of the data line **171** while being separated from the data line **171**.

In some embodiments, the first source electrode **176a** protrudes toward the first semiconductor **135a** from the data line **171**, and the second source electrode **176b** protrudes toward the second semiconductor **135b** from the driving voltage line **172**. In some embodiments, the first source electrode **176a** and the second source electrode **176b** are connected with the source regions **1356a** and **1356b** through the source contact holes **166**, respectively.

In some embodiments, the first drain electrode **177a** (not shown) faces the first source electrode **176a** and is connected with the drain region **1357a** through the drain contact hole **167**.

The first drain electrode **177a** (not shown) extends along the gate line, and is electrically connected with the second gate electrode **158b** through a contact hole **81**.

In some embodiments, the second drain electrode **177b** is connected with the drain region **1357b** through the drain contact hole **167**.

In some embodiments, the data line **171**, the driving voltage line **172**, and the first drain electrode **177a** may be formed as a single layer or a multilayer formed of a low resistance material, such as Al, Ti, Mo, Cu, Ni, or an alloy thereof, or a corrosion resistant material. For example, the data line **171**, the driving voltage line **172**, and the first drain electrode **177a** may be triple layers of Ti/Cu/Ti or Ti/Ag/Ti.

In an exemplary embodiment, the capacitor may be formed by overlapping the first capacitor electrode and the second capacitor electrode, but the capacitor having a metal/dielectric/metal structure may be formed by forming an electrode on the same layer as that of the data line or the same layer as that of the first electrode.

In some embodiments, a second interlayer insulating layer **180** is formed on the data line **171**, the driving voltage line **172**, the first drain electrode **177a** (not shown), and a first electrode **710**.

In some embodiments, the first electrode **710** and an auxiliary electrode **740** are formed on the second interlayer insulating layer **180**.

The first electrode **710** may be an anode of the organic light emitting element of FIG. 1. In some embodiments, the first electrode **710** is connected to the second drain electrode **177b** through a contact hole **82**.

In an exemplary embodiment, the second drain electrode **177b** and the first electrode **710** are connected through the contact hole **82** with the second interlayer insulating layer **180** interposed therebetween, but the second drain electrode **177b** and the first electrode **710** may be integrally formed.

In some embodiments, the auxiliary electrode **740** is separated from the first electrode **710**, overlaps at least one of the data line **171** and the driving voltage line **172**, and is elongated along with them. In some embodiments, the auxiliary electrode **740** may be applied with the same voltage as a second electrode **730** to reduce the voltage drop of the second electrode **730**.

In some embodiments, an absorption electrode **770** is formed on the auxiliary electrode **740**.

In some embodiments, the auxiliary electrode **740** is generally connected to the second electrode **730**, and to connect the auxiliary electrode **740** and the second electrode **730** to each other, an organic emission layer **720** disposed between the auxiliary electrode **740** and the second electrode **730** must be removed. In this configuration, the organic emission layer **720** has the low energy absorbency and the energy transmission efficiency is largely decreased such that the absorption electrode **770** easily absorbs the energy by being disposed between the organic emission layer **720** and the auxiliary electrode **740**, and thereby the organic emission layer **720** may be further simply removed by a method of vaporizing the organic emission layer **720** by increasing the temperature of the organic emission layer **720**.

In some embodiments, the absorption electrode **770** absorbs the energy when removing the organic emission layer **720** such that a material for the absorption electrode **770** must have the high energy absorbency, and the absorption electrode **770** is disposed between the auxiliary electrode **740** and the second electrode **730** such that the material must have conductivity for an electrical connection between the auxiliary electrode **740** and the second electrode **730**.

Accordingly, the absorption electrode **770** may be a metal material having high absorbency and conductivity and may be formed of one selected from molybdenum (Mo), titanium (Ti), tungsten (W), and chromium (Cr).

In some embodiments, the absorption electrode **770** may be formed with a thickness of 300-1500 Å, and the energy absorbency is excellent in this range.

In some embodiments, the absorption electrode **770** may be formed of the single layer or the multiple layers.

When the absorption electrode **770** is formed of a plurality layers, an oxide layer (not shown) may be formed between a plurality of absorption electrodes **770**.

In some embodiments, the oxide layer may be one selected from ITO or IZO, and may have a thickness of 400-800 Å.

Among the absorption electrode **770** of the plurality of layers, a lower layer may be thicker than an upper layer, and the upper layer of a thickness of 40-100 Å and the lower layer of a thickness of 300-1000 Å may be formed.

In some embodiments, a pixel definition layer **116** patterned with an insulating material exposing at least a portion of the first electrode **710** and the auxiliary electrode **740** and the entire portion of the absorption electrode **770** is formed on the entire substrate including the first electrode **710**, and the organic emission layer **720** including an emission layer is formed on the pixel definition layer **116** formed on the entire substrate including the first electrode **710** and the exposed portion of the first electrode **710**. In some embodiments, the organic emission layer **720** includes a contact hole **74** exposing the auxiliary electrode **740** and the absorption electrode **770**.

As shown in the exemplary embodiment of FIG. 2, a plurality of contact holes **74** are disposed with a uniform interval, however it may be elongated along with the auxiliary electrode **740**.

In some embodiments, the organic emission layer **720** may be formed of a low molecular weight organic material or a

high molecular weight organic material such as PEDOT ((poly)3,4-ethylenedioxythiophene). Further, the organic emission layer **720** may be formed of a multilayer including one or more of a hole injection layer (HIL), a hole transport layer (HTL), an electron transport layer (ETL), and an electron injection layer (EIL), and the emission layer. When all the layers are included, the hole injection layer (HIL) is disposed on the first electrode **710** as the anode, and the hole transport layer (HTL), the emission layer, the electron transport layer (ETL), and the electron injection layer (EIL) are sequentially laminated thereon.

In the organic emission layer **720**, a red organic emission layer, a green organic emission layer, and a blue organic emission layer may be laminated in a red pixel, a green pixel, and a blue pixel, respectively, and a red color filter, a green color filter, and a blue color filter may be formed for each pixel to embody a color image. As another example, a white organic emission layer emitting light having a white color may be formed in all of the red pixel, the green pixel, and the blue pixel, and the red color filter, the green color filter, and the blue color filter may be formed for each pixel to embody the color image.

For the organic emission layer **720** according to the present invention, the lamination structures of the red pixel, the blue pixel, and the green pixel are the same. Accordingly, a deposition mask for depositing the organic emission layer on each pixel, that is, the red pixel, the green pixel, and the blue pixel, may not be used.

The white organic emission layer described as another example may be formed of one organic emission layer, and even includes a constitution where a plurality of organic emission layers are laminated to emit light having the white color. For example, a constitution where at least one yellow organic emission layer and at least one blue organic emission layer are combined to emit light having the white color, a constitution where at least one cyan organic emission layer and at least one red organic emission layer are combined to emit light having the white color, or a constitution where at least one magenta organic emission layer and at least one green organic emission layer are combined to emit light having the white color may be included.

In some embodiments, the second electrode **730** is formed on an opening **99** exposing the organic emission layer **720** and the contact hole **74**.

In some embodiments, the second electrode **730** becomes a cathode of the organic light emitting element. Accordingly, the first electrode **710** and the absorption electrode **770**, the organic emission layer **720**, and the second electrode **730** form the organic light emitting element **70**.

In some embodiments, the second electrode **730** contacts an upper surface of the auxiliary electrode **740**, an upper surface and a side surface of the absorption electrode **770**, and an etched surface of the opening **99** in the contact hole **74**.

In some embodiments, the organic light emitting diode display may have any one structure among a top display type, a rear display type, and a both-side display type according to a direction in which the organic light emitting diode **70** emits light.

In the top display type of organic light emitting diode display according to the exemplary embodiment, the first electrode **710** is formed as a reflective layer, and the second electrode **730** is formed as a transparent layer or a semi-transparent layer.

In some embodiments, the reflective layer and the semi-transparent layer are formed of at least one metal among magnesium (Mg), silver (Ag), gold (Au), calcium (Ca), lithium (Li), chromium (Cr), and aluminum (Al), or an alloy

thereof. The reflective layer and the semi-transparent layer are determined by thickness, and the semi-transparent layer may be formed to have a thickness equal to or less than 200 nm. As the thickness is decreased, transmittance of light is increased, but when the thickness is excessively small, resistance is increased. In some embodiments, the transparent layer may be formed of a material such as indium tin oxide (ITO), indium zinc oxide (IZO), zinc oxide (ZnO), or indium oxide (In₂O₃).

As described above, when forming the auxiliary electrode **740** and the absorption electrode **770** that are connected to the second electrode **730**, the voltage drop of the driving voltage passing through the second electrode **730** that is formed on the entire substrate **100** may be minimized and the contact hole **74** may be simply formed.

An organic light emitting diode display according to another exemplary embodiment will be described with reference to FIG. **4**.

FIG. **4** is a layout view of one pixel of an organic light emitting diode display according to another exemplary embodiment of the present invention.

The exemplary embodiment shown in FIG. **4** is substantially the same as the exemplary embodiment shown in FIG. **2** and FIG. **3**, except for a formation position and a shape of the absorption electrode **770** such that the overlapping description of reference numerals is omitted.

As shown in the exemplary embodiment of FIG. **4**, an absorption electrode **771** of the organic light emitting diode display does not have the line shape parallel to the auxiliary electrode **740**, but the absorption electrode **771** may be formed with a dot shape on the auxiliary electrode **740**. In FIG. **4**, a plurality of absorption electrodes **771** have a quadrangle shape, however the shape of the absorption electrode may be various such as triangle or a polygon.

An organic light emitting diode display according to another exemplary embodiment will be described with reference to FIG. **5** and FIG. **6**.

FIG. **5** is a layout view of one pixel of an organic light emitting diode display according to the current exemplary embodiment of the present invention, and FIG. **6** is a cross-sectional view taken along the line VI-VI of FIG. **5**.

The exemplary embodiment shown in FIG. **5** and FIG. **6** is substantially the same as the exemplary embodiment shown in FIG. **2** and FIG. **3**, except that the auxiliary electrode **740** is replaced by the absorption electrode **770** such that the overlapping description of reference numerals is omitted.

In some embodiments, the absorption electrode **770** is separated from the first electrode **710**, overlaps at least one of the data line **171** and the driving voltage line **172**, and is elongated along with them. In some embodiments, the absorption electrode **770** with a function of the auxiliary electrode to reduce the voltage drop of the second electrode **730** may be applied with the same voltage as the second electrode **730**.

In some embodiments, the absorption electrode **740** is connected to the second electrode **730** to connect the absorption electrode **770** and the second electrode **730** to each other, the organic emission layer **720** disposed between the absorption electrode **770** and the second electrode **730** must be removed. In some embodiments, the organic emission layer **720** has the low energy absorbency and the energy transmission efficiency is largely decreased such that the absorption electrode **770** easily absorbs the energy by being disposed as the auxiliary electrode, and thereby the organic emission layer **720** may be further simply removed by the method of vaporizing the organic emission layer **720** by increasing the temperature of the organic emission layer **720**.

In some embodiments, the absorption electrode **770** absorbs the energy when removing the organic emission layer **720** such that the material for the absorption electrode **770** must have high energy absorbency, and the absorption electrode **770** has the function of the auxiliary electrode such that the material must have conductivity for an electrical connection between the absorption electrode **770** and the second electrode **730**.

Accordingly, the absorption electrode **770** may be the metal material having the high absorbency and the conductivity and may be formed of one selected from molybdenum (Mo), titanium (Ti), tungsten (W), and chromium (Cr).

In some embodiments, the absorption electrode **770** may be formed with a thickness of 300-1500 Å, and the energy absorbency is excellent in this range.

In some embodiments, the absorption electrode **770** may be formed of the single layer or the multiple layers.

In some embodiments, an oxide layer (not shown) may be formed between a plurality of absorption electrodes **770** when the absorption electrode **770** is formed of multiple layers.

In some embodiments, the oxide layer may be one selected from ITO or IZO, and may have a thickness of 400-800 Å.

In this configuration, among the absorption electrode **770** of the plurality of layers, a lower layer may be thicker than an upper layer, and the upper layer of a thickness of 40-100 Å and the lower layer of a thickness of 300-1000 Å may be formed.

In some embodiments, the organic emission layer **720** is formed on the entire substrate including the first electrode **710**. In some embodiments, the organic emission layer **720** includes the contact hole **74** exposing the absorption electrode **770** functioning as the auxiliary electrode.

Next, a method manufacturing the organic light emitting diode display will be described in detail with reference to FIG. **7** to FIG. **13** as well as FIG. **2** and FIG. **3**.

FIGS. **7** to **13** are cross-sectional views sequentially showing a manufacturing method of an organic light emitting diode display according to another exemplary embodiment of the present invention.

As shown in FIG. **7**, the buffer layer **120** is formed on a substrate **100**. In some embodiments, the buffer layer **120** may be formed of a silicon nitride or a silicon oxide.

After forming a polysilicon film on the buffer layer **120**, the first semiconductor **135a**, the second semiconductor **135b**, and the first capacitor electrode **138** are formed by patterning the polysilicon film.

Next, as shown in FIG. **8**, the gate insulating layer **140** may be formed on the first semiconductor **135a** and the second semiconductor **135b**. In some embodiments, the gate insulating layer **140** may be formed of a silicon nitride or a silicon oxide.

Furthermore, after stacking a metal film on the gate insulating layer **140**, the first and second gate electrodes **155a** and **155b** and the second capacitor electrode **158** are formed by patterning the metal film.

In some embodiments, the source region, the drain region, and the channel region may be formed by doping conductive impurities into the first semiconductor **135a** and the second semiconductor **135b** by using the first gate electrode **155a** and the second gate electrode **155b** as a mask. In some embodiments, prior to the formation of the first gate electrode **155a** and the second gate electrode **155b**, the conductive impurities can also be doped into the first capacitor electrode **138** using a photoresist film. Furthermore, if each of the first gate electrode **155a** and the second gate electrode **155b** is formed of a dual layer and the second capacitor electrode **158** is formed of

a single layer, the conductive impurities can also be doped into the first capacitor electrode **138** along with the source region and the drain region.

As shown in FIG. 9, the interlayer insulating layer **160** having the contact holes **166** and **167** through which the source region and the drain region are respectively exposed is formed on the first and second gate electrodes **155a** and **155b** and the second capacitor electrode **158**. In some embodiments, the interlayer insulating layer **160** can be made of tetraethyl orthosilicate (TEOS), a silicon nitride, or a silicon oxide. Furthermore, the interlayer insulating layer **160** can be made of a low dielectric constant material in order to make the substrate flat.

Next, as shown in FIG. 10, ITO/Ag/ITO is deposited and patterned on the interlayer insulating layer **160** to form the first electrode **710** and the auxiliary electrode **740**.

Next, as shown in FIG. 11, the absorption electrode **770** is formed on the auxiliary electrode **740**.

In some embodiments, the absorption electrode **770** absorbs the energy when removing the organic emission layer **720** such that the material for the absorption electrode **770** must have the high energy absorbency, and the absorption electrode has the function of the auxiliary electrode **740** such that the material must have conductivity for the electrical connection between the absorption electrode **770** and the second electrode **730**.

Accordingly, the absorption electrode **770** may be the metal material having the high absorbency and the conductivity and may be formed of one selected from molybdenum (Mo), titanium (Ti), tungsten (W), and chromium (Cr).

In some embodiments, the absorption electrode **770** may be formed with a thickness of 300-1500 Å, and the energy absorbency is excellent in this range.

In some embodiments, the absorption electrode **770** may be formed of the single layer or the multiple layers.

When the absorption electrode **770** is formed of multiple layers, an oxide layer (not shown) may be formed between a plurality of absorption electrodes.

The oxide layer may be one selected from ITO or IZO, and may have a thickness of 400-800 Å.

In this configuration, among the absorption electrode **770** of the plurality of layers, a lower layer may be thicker than an upper layer, and the upper layer of the thickness of 40-100 Å and the lower layer of the thickness of 300-1000 Å may be formed.

In some embodiments, the absorption electrode **770** may be formed with the line shape parallel to the auxiliary electrode **740**, as shown in FIG. 4, may be formed with the dot shape on the auxiliary electrode **740**.

In some embodiments, the absorption electrode **770** absorbs the energy when removing the organic emission layer **720** such that the material for the absorption electrode **770** must have the high energy absorbency, and the absorption electrode **770** is disposed between the auxiliary electrode **740** and the second electrode **730** such that the material must have conductivity for an electric connection between the auxiliary electrode **740** and the second electrode **730**.

Accordingly, the absorption electrode **770** may be a metal material having high absorbency and conductivity and may be formed of one selected from molybdenum (Mo), titanium (Ti), tungsten (W), and chromium (Cr).

In some embodiments, the absorption electrode **770** may be formed with a thickness of 300-1500 Å, and the energy absorbency is excellent in this range.

In some embodiments, the absorption electrode **770** may be formed of the single layer or the multiple layers.

When the absorption electrode **770** is formed of multiple layers, an oxide layer (not shown) may be formed between a plurality of absorption electrodes **770**.

The oxide layer may be one selected from ITO or IZO, and may have a thickness of 400-800 Å.

At this time, among the absorption electrode **770** of the plurality of layers, the lower layer may be thicker than the upper layer, and the upper layer of the thickness of 40-100 Å and the lower layer of the thickness of 300-1000 Å may be formed.

Next, as shown in FIG. 12, on the first electrode **710**, the auxiliary electrode **740**, and the absorption electrode **770**, the pixel definition layer **116** patterned with the insulating material is formed to expose at least a portion of the first electrode **710** and the auxiliary electrode **740**, and the entire absorption electrode **770**, and the organic emission layer **720** is deposited on the pixel definition layer **116**, the exposed first electrode **710**, the auxiliary electrode **740**, and the absorption electrode **770**.

In some embodiments, the organic emission layer **720** is formed on the entire substrate without a separate mask, and a hole auxiliary layer, a red organic emission layer, a green organic emission layer, a blue organic emission layer, and an electron auxiliary layer may be sequentially deposited.

Next, a light source having energy having a wavelength region to be absorbed into the absorption electrode **770** to etch the organic emission layer **720**, and the second electrode **730** having the opening **99** exposing the auxiliary electrode **740** and the absorption electrode **770** and the contact hole **74**, are formed.

Conventionally, a laser is used when etching the organic emission layer **720**, however, when manufacturing the organic light emitting diode display according to an exemplary embodiment, the energy absorbency of the absorption electrode **770** is high such that a laser, a flash lamp, a tungsten halogen lamp, etc., may be used as an energy light source used to etch the organic emission layer **720**.

In some embodiments, the energy irradiated by the light source is easily absorbed to the absorption electrode **770** such that the temperature of the absorption electrode **770** is increased, and at this time, the organic emission layer **720** formed on the absorption electrode **770** may be etched by the method of increasing the temperature of the organic emission layer **720** and evaporating the organic emission layer **720**.

In some embodiments of the manufacturing of the organic light emitting diode display, the method of increasing the temperature of the organic emission layer **720** and evaporating the organic emission layer **720** by using the absorption electrode **770** is performed in the etching process to form the opening **99** in the organic emission layer **720** such that a patterning mask for the etching of the organic emission layer **720** may be omitted.

Next, as shown in FIG. 13, a metal layer is formed on the entire substrate to form the second electrode **730** on the organic emission layer **720** and connected to the auxiliary electrode **740** and the absorption electrode **770** exposed through the opening **99** of the organic emission layer **720**.

In some embodiments, the metal layer as the semi-transparent layer may be formed by depositing a Mg—Ag alloy. In some embodiments, the second electrode **730** is formed with a thickness of about 500 nm.

Exemplary Embodiment 1

When Forming an Absorption Electrode of a Single Layered Structure, Absorbency Measuring According to Wavelength

The energy absorbency of the light irradiated from the energy light source is measured when forming the absorption

13

electrode of the single layer in the organic light emitting diode display according to an exemplary embodiment of the present invention.

In some embodiments, a flash lamp is used as the energy light source.

In some embodiments, the material of the absorption electrode is molybdenum (Mo), the absorbency is measured for the thicknesses 250 Å, 500 Å, 1000 Å, and 1500 Å of the absorption electrode, and a result thereof is shown in FIG. 14.

In the graph shown in FIG. 14, the horizontal axis represents a wavelength of the light source and the vertical axis represents the energy absorbency of the light source. As shown in FIG. 14, in the absorption electrode of the single layer, it may be confirmed that the absorbency of the light source energy is more than 50% in the thickness of the absorption electrode of more than 500 Å in the visible light region.

Exemplary Embodiment 2

When Forming an Absorption Electrode of a Single Layered Structure, Absorbency Measuring According to Wavelength

In the organic light emitting diode display according to another exemplary embodiment, the energy absorbency of the light irradiated from the energy light source is measured when forming the absorption electrode of the multiple layers.

In some embodiments, the energy light source uses the flash lamp.

In some embodiments, the material for the absorption electrode uses the dual layer of molybdenum (Mo), the thickness of the upper absorption electrode is 40 Å and 60 Å, and the thickness of the lower absorption electrode is 350 Å. The oxide layer between the upper and lower absorption electrodes uses ITO, and the thickness of the oxide layer is respectively 450 Å, 500 Å, 550 Å, 600 Å, and 700 Å to measure of the energy absorbency of the light source, and the result thereof is shown in FIG. 15.

In the graph shown in FIG. 15, the horizontal axis represents the wavelength of the light source and the vertical axis represents the energy absorbency of the light source. As shown in FIG. 15, in the absorption electrode of the multiple layers, it may be confirmed that the energy absorbency of the light source is more than 65% in the visible light region.

The organic light emitting diode (OLED) display according to an exemplary embodiment may minimize the voltage drop of the driving power passing through the large-sized electrode of the thin film for driving the organic emission layer, and may simplify the removal process of the organic emission layer on the auxiliary electrode by adding the absorption electrode on the auxiliary electrode.

While one or more embodiments of the present disclosure has been described in connection with what is presently considered to be practical exemplary embodiments, it is to be understood that the embodiments are not limited to the disclosed exemplary embodiments and is intended to cover various modifications and equivalent arrangements included within the spirit and scope of the appended claims.

What is claimed is:

1. An organic light emitting diode display comprising: a substrate; a first electrode and an auxiliary electrode positioned on the substrate and separated from each other; an absorption electrode positioned on the auxiliary electrode;

14

an organic emission layer positioned on the first electrode and having a contact hole exposing the auxiliary electrode and the absorption electrode; and

a second electrode positioned on the organic emission layer and connected to the auxiliary electrode and the absorption electrode through the contact hole;

wherein the second electrode contacts an etched surface of the contact hole, an upper surface of the auxiliary electrode, and an upper surface and a side surface of the absorption electrode.

2. The organic light emitting diode display of claim 1, wherein

the absorption electrode is made of one selected from molybdenum (Mo), titanium (Ti), tungsten (W), and chromium (Cr).

3. The organic light emitting diode display of claim 2, wherein

the absorption electrode is formed of a single layer or multiple layers.

4. The organic light emitting diode display of claim 3, wherein

when the absorption electrode is formed of a single layer, the absorption electrode has a thickness of 300-1500 Å.

5. The organic light emitting diode display of claim 3, wherein

an oxide layer is further formed between the absorption electrode of the multiple layers when the absorption electrode is formed of multiple layers.

6. The organic light emitting diode display of claim 5, wherein

the absorption electrode is formed of dual layers, and an upper layer and a lower layer of the absorption electrode respectively have thicknesses of 40-100 Å and 300-1000 Å.

7. The organic light emitting diode display of claim 5, wherein

the oxide layer is ITO or IZO.

8. The organic light emitting diode display of claim 1, wherein

the absorption electrode is formed with a line shape or a dot shape in a direction parallel to the auxiliary electrode on the auxiliary electrode.

9. An organic light emitting diode display comprising:

a substrate;

a first electrode and an auxiliary electrode positioned on the substrate and separated from each other;

an absorption electrode positioned on the auxiliary electrode;

an organic emission layer positioned on the first electrode and having a contact hole exposing the auxiliary electrode and the absorption electrode;

a second electrode positioned on the organic emission layer and connected to the auxiliary electrode and the absorption electrode through the contact hole

a gate line positioned on the substrate;

a data line and a driving voltage line insulated from and intersecting the gate line and separated from each other; a switching thin film transistor connected to the gate line and the data line; and

a driving thin film transistor connected to the switching thin film transistor and the driving voltage line, wherein the first electrode is connected to a drain electrode of the driving thin film transistor.

10. An organic light emitting diode display comprising:

a substrate;

a first electrode and an absorption electrode made of one selected from molybdenum (Mo), titanium (Ti), tung-

15

sten (W), and chromium (Cr), positioned on the substrate and separated from each other;
 an organic emission layer positioned on the first electrode and a contact hole exposing the absorption electrode;
 a second electrode positioned on the organic emission layer and connected to the absorption electrode through the contact hole,
 wherein the absorption electrode is connected to the second electrode thereby having a function of an auxiliary electrode of the first electrode;
 a gate line positioned on the substrate;
 a data line and a driving voltage line insulated from and intersecting the gate line and separated from each other;
 a switching thin film transistor connected to the gate line and the data line; and
 a driving thin film transistor connected to the switching thin film transistor and the driving voltage line,
 wherein the first electrode is connected to a drain electrode of the driving thin film transistor.

11. The organic light emitting diode display of claim 9, wherein the absorption electrode is formed of a single layer or multiple layers.

12. The organic light emitting diode display of claim 11, wherein the absorption electrode is formed of a single layer, the absorption electrode has a thickness of 300-1500 Å.

16

13. The organic light emitting diode display of claim 11, wherein

an oxide layer is further formed between the absorption electrode of the multiple layers when the absorption electrode is formed of multiple layers.

14. The organic light emitting diode display of claim 10, wherein

the absorption electrode is formed of a single layer or multiple layers.

15. The organic light emitting diode display of claim 14, wherein

when the absorption electrode is formed of a single layer, the absorption electrode has a thickness of 300-1500 Å.

16. The organic light emitting diode display of claim 14, wherein

an oxide layer is further formed between the absorption electrode of the multiple layers when the absorption electrode is formed of multiple layers.

17. The organic light emitting diode display of claim 16, wherein

the absorption electrode is formed of dual layers, and an upper layer and a lower layer of the absorption electrode respectively have thicknesses of 40-100 Å and 300-1000 Å.

* * * * *

| | | | |
|----------------|----------------------------------------------------------------------------------------------------------------------------------------------------------------------------|---------|------------|
| 专利名称(译) | 具有辅助电极的有机发光二极管显示器 | | |
| 公开(公告)号 | US9159946 | 公开(公告)日 | 2015-10-13 |
| 申请号 | US14/205088 | 申请日 | 2014-03-11 |
| [标]申请(专利权)人(译) | 三星显示有限公司 | | |
| 申请(专利权)人(译) | 三星DISPLAY CO., LTD. | | |
| 当前申请(专利权)人(译) | 三星DISPLAY CO., LTD. | | |
| [标]发明人 | CHOI JIN BAEK BANG HYUN SUNG LEE YEON HWA LEE JOON GU CHOUNG JI YOUNG SONG YOUNG WOO | | |
| 发明人 | CHOI, JIN BAEK BANG, HYUN SUNG LEE, YEON HWA LEE, JOON GU CHOUNG, JI YOUNG SONG, YOUNG WOO | | |
| IPC分类号 | H01L51/52 H01L51/56 H01L27/32 | | |
| CPC分类号 | H01L51/5203 H01L27/3244 H01L51/56 H01L2251/5315 H01L51/5212 H01L51/5284 H01L27/3279 H01L51/0016 H01L2251/558 H05B33/26 H01L27/3248 H01L51/0017 H01L51/5228 H01L2251/308 | | |
| 优先权 | 1020130122831 2013-10-15 KR | | |
| 其他公开文献 | US20150102294A1 | | |
| 外部链接 | Espacenet USPTO | | |

摘要(译)

一方面，一种有机发光二极管显示器，包括：基板；第一电极和辅助电极，位于基板上并彼此分开；位于辅助电极上的吸收电极；有机发光层，位于第一电极上，具有暴露辅助电极和吸收电极的接触孔；第二电极设置在有机发光层上并通过接触孔连接到辅助电极和吸收电极。在一个方面，有机发光二极管（OLED）显示器可以使通过用于驱动有机发光层的薄膜的大尺寸电极的驱动功率的电压降最小化，并且可以简化有机发光的去除过程。通过在辅助电极上添加吸收电极在辅助电极上形成层。

